

# CentroGlide User Manual



## **IMPORTANT**

For your safety and comfort, please read carefully and understand all the features prior to using your new CentroGlide. Misuse may result in injury or electrical and/or mechanical damage.

**GLIDE**

# TABLE OF CONTENTS

<b>1. Introduction</b>	1
<b>2. Intended Use</b>	3
<b>3. Weight Limits of CentroGlide Power Chairs</b>	3
<b>4. Safety Guidelines for Users and Carers</b>	4
4.1 General Guidelines	4
4.1.1 <i>To the User/Occupant</i>	4
4.1.2 <i>To the Carer/Attendant</i>	5
4.1.3 <i>Safety / Performance Check Before Use</i>	6
4.2 Environment Conditions	7
4.2.1 <i>Accidental Movement</i>	7
4.2.2 <i>Loss of Traction</i>	7
4.2.3 <i>Using the Power Chair in Tilt / Recline Positions</i>	8
4.2.4 <i>Navigating Curbs and Other Obstacles</i>	8
4.2.5 <i>Wet/Damp Environments</i>	8
4.2.6 <i>Rough Surfaces</i>	8
4.2.7 <i>Emergency Stop</i>	9
4.2.8 <i>Ramps and Inclines</i>	9
4.2.9 <i>EMI (Electro-Magnetic Interference)</i>	11
4.2.10 <i>Risk of Injury from Hot Surfaces</i>	11
4.2.11 <i>Wheelchair Modifications</i>	11
<b>5. Parts and Accessories</b>	12
5.1 Common Parts	12
5.2 Joystick and Controller	13
5.2.1 <i>PG Joystick</i>	13
5.2.2 <i>LiNX Joystick</i>	14
5.2.3 <i>Optional Attendant Controller</i>	16
5.2.4 <i>LiNX REM400 Touchscreen</i>	17
5.2.5 <i>Controller Use Precautions</i>	18
5.2.6 <i>Replacing and Servicing Controllers</i>	19
5.3 Motor Drive - Engage/Disengage	20
5.3.1 <i>Type A - Motor Disengagement</i>	20
5.3.2 <i>Type B – Drive Wheel Clutch Disengagement</i>	21
5.4 Brakes	22

5.5 Batteries	23	10.7.2 Dahl / CentroGlide Adaptation Kit #502237 Installation	44
5.5.1 Battery Installation and Removal Procedure	23	10.7.3 CentroGlide Adaptation Kit	45
5.5.2 Battery Wiring Diagram	24	10.7.4 Dahl Docking system Mk II. Set-up	46
5.5.3 Battery Installation Warnings	25	10.7.5 Securing the Wheelchair in the Docking Station	47
5.5.4 Battery Charging	26	10.7.6 Releasing the Wheelchair from the Docking Station	48
5.5.5 Battery Care and Storage	27	10.7.7 Manual Release of Wheelchair from Docking Stations in Case of Electric Failure	48
<b>6. Wheelchair Setup and Adjustments</b>	28	10.7.8 Installation of the Dahl Docking Stations in the Vehicle	49
6.1 User/Attendant Training	28	10.8 Wheelchair Set-up for Occupant Transport	50
6.2 Armrests Adjustment	28	10.9 Occupant Restraints	51
6.2.1 Height Adjustment	29	10.9.1 Occupant Restraint Instructions for Use	51
6.2.2 Forward and Back Adjustment of Arm Pad	29	10.9.2 Positioning Occupant Restraint Using the Four-Strap Tie-down	53
6.2.3 Flip Up Armrest Lock	29	10.9.3 Positioning Occupant Restraint Using Dahl Docking System Only	53
6.3 Footrests and Footplates Adjustment	30	10.10 Postural Support Devices	54
6.3.1 Height Adjustment of the Footplates	30	10.11 Untested Seating / Backrest	55
6.4 Adjusting the Backrest Angle (Recline)	30	10.12 Power Reclining back	55
6.5 Adjusting the Seat Angle (Tilt)	31	<b>11. Care Maintenance and Repairs</b>	56
6.6 Positioning Belts	31	11.1 Maintenance Schedule	56
6.7 Power Seat Tilt	31	11.2 Cleaning Wheelchair and Parts	57
6.8 Power Reclining Backrest	32	11.3 Using a High-Pressure Water Cleaner	58
6.9 Other Power Options	32	11.4 Packing & Shipping the Centroglide Power Chair	58
6.10 Adjusting the Seat Frame Stop - Service Technicians Only	33	11.5 User Serviceable Parts / Spare Parts	59
<b>7. Transferring To and From the Wheelchair</b>	34	11.6 Puncture Repair	60
<b>8. Safe Operation of the power chair</b>	35	11.6.1 Replacing the Inner Tube on Mid Drive Wheel	60
<b>9. Vertical Lift (VL) and LAR Models</b>	36	11.7 Removing the Castor Wheel	62
<b>10. Transporting Wheelchair Occupant in a Motor Vehicle</b>	37	11.7.1 Tools required	62
10.1 Safety Considerations	37	11.7.2 Removal Procedure	62
10.2 Crash Test	38	11.7.3 Reassembly Procedure	62
10.3 Determining Motor Vehicle Size and Type	38	11.7.4 Replacing the Inner Tube on the Castor Wheel	63
10.4 Occupant Vehicle Transport Maximum User Weight	39	<b>12. Troubleshooting</b>	64
10.5 Wheelchair Securement	39	12.1 Power Chair Will Not Drive	64
10.6 Four-Point Strap-Type Tie-Down System	40	12.2 Power Chair Speed Suddenly Dropped	64
10.6.1 Securing the Wheelchair with a Four-Point Strap-Type Restraint	40	<b>13. Warranty</b>	65
10.6.2 Tie-Down Strap Angles	41	13.1 Limitation of Liability and Exclusions	66
10.6.3 Wheelchair Tie-down Locations Four-Point	41	<b>14. Technical Specifications</b>	68
10.7 Dahl Docking Station	42	<b>15. Disposal and Recycling</b>	69
10.7.1 Fitting of the Dahl Lock Plate onto the Wheelchair	43		

## 1. INTRODUCTION

Thank you for choosing the CentroGlide Power Wheelchair. This Australian-designed and manufactured product complies with AS3695 and AS3696.19 for both four-point tie-down systems and Dahl Docking Station for Wheeled Mobility Devices for use as a Seat in a Motor Vehicle.

The CentroGlide is a robust mid-wheel-drive power chair, designed to provide remarkable stability and trouble-free service for years.

It comes with our Active Pozi-Track (APT), which is a 6-wheel fully independent suspension system.

The CentroGlide model range is a Class B type wheelchair. It is designed to be manoeuvrable, narrow and compact - perfect for use both indoors and outdoors with a 75 amp battery system.

All CentroGlide wheelchairs have built-in, tilt in space, and come with a completely customisable seating platform to allow for tailored cushioning.

This User Manual covers all CentroGlide models. The suitability of a particular model for the occupant/user can only be determined by a suitably qualified medical practitioner.

NOTE: If you have purchased a **Vertical Lift (VL)** model, it is essential you read and fully understand Section 9 of this User Manual before use.

This manual contains important information regarding the safety, operation and maintenance of the CentroGlide. Please read it carefully to familiarise yourself with the functions and features of your wheelchair and follow the safety instructions.

Note that, although some settings and maintenance procedures can be performed by the user or their attendant/carer, others will require technical expertise and should only be carried out by the Glide Products-approved technicians/agents. Damage caused by non-observance of the instructions in this User Manual, or as a result of the incorrect maintenance, will void the warranty.

With proper care and operation, your wheelchair will provide you with many years of excellent mobility.

** WARNING!**

This symbol is used in this manual to indicate hazards or practices that could result in an injury or damage to the wheelchair and/or property. You must understand and follow these warnings.

If you have any questions regarding the functions of this wheelchair, please contact Glide Products or your nearest Glide Products agent.

**Glide Products**  
**66 Prindiville Drive, Wangara**  
**Western Australia 6065**  
**Australia**  
**PH +61 8 9345 3400**  
**Fax +61 8 9345 1384**

## 2. INTENDED USE

The Glide Products CentroGlide intended use is to provide assisted mobility to occupants limited to a seated position.

** WARNING!**

DO NOT use the wheelchair for purposes other than those intended by the manufacturer, Glide Products Pty. Ltd.

## 3. WEIGHT LIMITS OF CENTROGLIDE POWER CHAIRS

** WARNING!**

The following weight limits must be observed for all power chairs in the CentroGlide range.

**CentroGlide TS, ER, XT and VL - Maximum User Weight 175 kg**

**CentroGlide Bariatric - Maximum User Weight 250 kg**

**CentroGlide LA and LAR - Maximum User Weight 150 kg**

These are the combined weight limits of the occupant and any items carried on the wheelchair by the occupant or attendant/carer. If the weight limit is exceeded, damage to the chair, or injury to the occupant and/or others may occur.

## 4. SAFETY GUIDELINES FOR USERS AND CARERS

### 4.1 General Guidelines

#### WARNING!

For safe operation and use of the CentroGlide, please read and understand the safety warnings stated in this manual. Improper use of the wheelchair may cause injury or damage. If you are uncertain about any aspect of operation of the chair, please consult the relevant healthcare professional or your nearest Glide Products agent.

#### 4.1.1 To the User/Occupant

#### WARNING!

- Before using this chair, obtain advice and training from your healthcare professional.
- Each chair is custom designed to suit individual needs. Take time to become familiar with each feature before you begin driving.
- Depending on your level of function and ability, you will need to develop your own methods to use the wheelchair safely.
- Understanding the environment where the wheelchair will be used will help identify potential hazards so you can learn to avoid them.
- Read this manual in full before operating the chair.
- When traversing curbs or steps always approach square on. Never attempt an angled approach as this may damage the castors.
- Never drive the wheelchair onto stairs or escalators. Always use lifts or ramps.

#### 4.1.2 To the Carer/Attendant

#### WARNING!

- Read this manual in full before operating the chair, and follow all the instructions in each section as they also apply to you.
- Never use power-operated options such as Vertical Lift or Power Elevators unless the occupant and all bystanders have their hands well clear of the operation.
- **Drive Clutches or Motor Brakes should be engaged at all times while the occupant is seated. When drive clutches are disengaged there is no braking when manoeuvring the wheelchair.**
- To manually push the chair, you must make sure that you have control over the wheelchair before releasing the Motor Drive Clutch. Only manually manoeuvre the wheelchair on level ground while the occupant is seated in the wheelchair. **Never manually manoeuvre the wheelchair up and down ramps whilst the occupant is seated in the wheelchair.**
- You must develop an understanding of the occupant's specific needs and limitations to develop safe methods of operating the wheelchair best suited to your ability. Seek advice from the relevant healthcare professional on how to safely move the chair with an occupant to prevent injury.
- Only use the push handles to move the chair. They are specifically designed for this purpose.
- When helping the occupant overcome an obstacle you must:
  1. Learn safe methods of operation from your healthcare professional.
  2. Explain clearly to the occupant what you are about to do and what they are required to do.
  3. When traversing curbs or steps always approach square on. Never attempt angled approaches as this may damage the castors.
- Never take the wheelchair onto stairs or escalators. Use lifts or ramps.

### 4.1.3 Safety / Performance Check Before Use

#### **WARNING!**

- Make sure the chair operates as it was designed to. In case of damage, change in the performance of the wheelchair or change in your functional ability, contact your nearest Glide Products agent to reprogram the control settings to match your needs. It is advisable to have these settings checked annually.
- Check for any uncharacteristic noises, vibrations or any difficulty in its use. If a problem is found, notify your carer and Glide Product agent for repair or advice on how to repair it. Do not drive the wheelchair if your safety is at risk.
- Make sure that the batteries are fully charged before operating.
- Make sure all tyres are inflated to recommended pressures and in good condition.
- Make sure all accessories are secure and in the correct positions.
- Check that the electronic brakes work correctly. (When the wheelchair is switched ON with the drive clutch engaged, and the hand is off the joystick, the wheelchair should not be able to be pushed.)

### 4.2 Environment Conditions

#### **WARNING!**

The Glide Products Power Chair has been designed and tested with user safety as its prime consideration.

The “Active Posi Trak” (APT) Suspension System has been designed to automatically adjust to uneven surfaces and changes in height, allowing all six wheels to stay in contact with the ground under most conditions. This feature provides improved stability and increased traction on drive wheels in demanding situations. Even though the “Active Posi Trak” System improves manoeuvrability and stability, this does not negate the effect or take into account circumstances that put the wheelchair outside the specified operating conditions for which it was designed and tested.

It is important for both users and carers to take due care and understand the limitations of the environment that the chair will be operated in.

As a guide only, the following is a brief list of scenarios that could affect the stability or operation of the chair and need to be considered when driving the chair.

#### **4.2.1 Accidental Movement**

##### **WARNING!**

- Always turn the controller OFF when parked. Even if it is only for a short time, as this will prevent accidental movement of the chair or the release of park brakes.
- The wheelchair must remain in the Engaged Drive Mode at all times unless you are manually manoeuvring the wheelchair.

#### **4.2.2 Loss of Traction**

##### **WARNING!**

- Traction could be lost on inclined / declined wet, oily or grassy surfaces. Take extra care and drive slowly on these surfaces. Stop, if one or both drive wheels lose traction.
- DO NOT drive your chair on an ice-covered ramp or incline.



### 4.2.3 Using the Power Chair in Tilt / Recline Positions

#### **WARNING!**

- Extreme tilting and reclining must be done on level ground ONLY.
- Chairs fitted with Tilt and Recline features should NOT be driven with these features in extreme Tilt or Recline positions. Driving in a Tilted or Reclined position can affect your chair's stability and visibility.

### 4.2.4 Navigating Curbs and Other Obstacles

#### **WARNING!**

- If your environment has many steep obstacles, always have someone in attendance to assist you.
- Curb climbing should not exceed 80mm when level. Do not climb if the chair is already on a slope.
- Curb descending should not be more than 100mm when level. Do not descend if the chair is already on a slope.
- Always approach the curbs square on, never on an angle. The castors will spin and lock if the approach angle is not 90 degrees.
- DO NOT traverse railway lines without someone in attendance.

### 4.2.5 Wet/Damp Environments

#### **WARNING!**

- DO NOT drive your wheelchair in heavy rain.
- DO NOT use your chair in a shower, swimming pool, sauna, ocean or lake.

### 4.2.6 Rough Surfaces

#### **WARNING!**

- Avoid driving your wheelchair in sand or over rough surfaces. Apart from getting stuck, you may also cause damage to wheels, bearings, gearboxes and motors.

### 4.2.7 Emergency Stop

#### **WARNING!**

Whilst driving, the ON/OFF switch on the controller should only be switched OFF in an emergency. The wheelchair will come to a fast controlled stop rather than a sudden stop.

### 4.2.8 Ramps and Inclines

#### **WARNING!**

When your chair is on a ramp or incline the centre of balance of your chair will change. Your chair is less stable when on ramps or inclines and should not be used unless you feel it is safe to do so. If in doubt have someone with you.

Do not use the chair on an up OR down slope greater than 15 degrees.

#### Going Up the Ramp:

- Make sure the Power Seat Tilt is in the down or flat position and the backrest is in the upright position.
- Never attempt climbing ramps with a high degree of seat tilt.
- Approach the ramp or incline straight on. Do not approach at an angle (cut the corner).
- Make sure that you are in the centre of the ramp and that the ramp is wide enough for your wheelchair.
- Do not use the ramp if you feel that a wheel may drop off the side.
- Do not veer or turn while on a ramp. This may cause the chair to tip and fall. Drive the wheelchair at a slow, steady speed. Keep it moving up the ramp.
- Return Tilt and Recline to normal driving position when back on level ground.



### **Going Down the Ramp:**

- Raise the Power Seat Tilt to a suitable angle to compensate for the ramp angle. The seat angle should be close to level position when the wheelchair is on the ramp or, even better, slightly raised. This will reduce the chance of your body falling forward when travelling down a ramp.
- Re-adjust the seat tilt angle to your normal drive position when you're back on level ground.
- Always use the centre of the ramp.
- Do not veer or turn while on the ramp.
- Drive the wheelchair at a slow steady speed. Do not allow the chair to accelerate over the normal speed. Centre the joystick to allow it to slow down or stop.
- Never use the Attendant Brakes to slow or stop the chair. This may cause the chair to veer or change direction erratically.

### **4.2.9 EMI (Electro-Magnetic Interference)**

#### **WARNING!**

EMI (Electro-Magnetic Interference) comes from Radio Waves like Cellular phones, CB Radios and Two Way Radio. Other sources, including Transmitters from TV and Radio stations, are unlikely to interfere with the function of the chair unless you are in close proximity to the transmitter.

EMI can cause your wheelchair to behave erratically or even more so, release brakes or move by itself unexpectedly. If this happens, immediately turn your wheelchair OFF.

Before continuing, the user must be confident that the system is performing normally. If not, turn the wheelchair OFF and contact your carer or Glide Products agent.

Although Glide has not had any reported instances of EMI, there has been anecdotal evidence over many years that EMI can have an impact on power chair controllers.

### **4.2.10 Risk of Injury From Hot Surfaces**

#### **WARNING!**

DO NOT leave the chair in direct sunlight or next to a heat source, such as a fireplace, for extended periods. Increase in surface temperature may burn your skin and damage your chair.

### **4.2.11 Wheelchair Modifications**

#### **WARNING!**

Never make any modifications or use non-approved Glide Products parts on your power chair. Doing so may result in serious injury or damage and could void the Warranty.

Unauthorised changes could also constitute a re-manufacturing of the power chair, with the person or group making the changes assuming full liability for the power chair. Any replacement parts must match the original Glide Products parts.

## 5. PARTS AND ACCESSORIES

### 5.1 Common Parts

The illustration below shows the common parts of the CentroGlide Power chair range.

1. Attendant Joystick (optional)	12. Drive Wheel Clutch (optional)
2. Joystick	13. Attendant Brake
3. Seat Pan	14. Castor Wheel (rear)
4. Leg Rest Hanger	15. Rear Suspension Arm
5. Leg Rest Latch	16. Rear Vehicle Tie-down Point
6. Front Suspension Arm	17. Circuit Breaker (Reset)
7. Foot Rest (Adjust Angle shown)	18. Armrest (flip-up)
8. Front Vehicle Tie-down point	19. Actuator (Recline)
9. Castor Wheel (front)	20. Armrest
10. Motor Brake release	21. Back Cane
11. Drive Wheel	22. Hand Grip

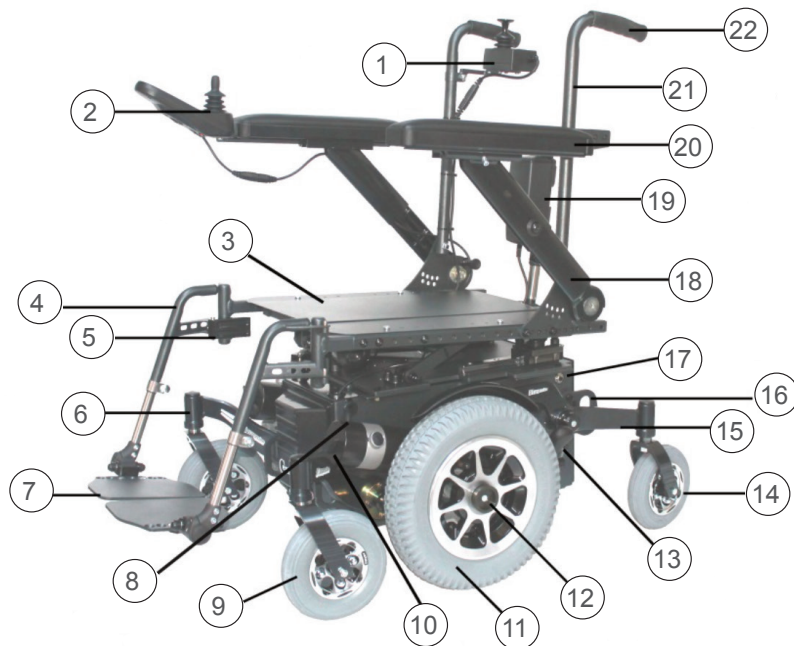

### 5.2 Joystick and Controller

The CentroGlide will be supplied with either a **PG** or **LiNX** fully programmable controller which can fine-tune many driving parameters using special equipment and a PC. Although the two systems are from different manufacturers, their operations are very similar.

At the time of specification, your chair would have been programmed to best suit your function and ability.

**⚠ WARNING!** • Drive the chair in the mode and speed level that best suits the environment so as not to cause injury to yourself or others.

**⚠ WARNING!** • Only authorised Glide Products agents should make adjustments to the controller if the chair is not performing to your satisfaction. There are no controller adjustments that can be made by the user or carer apart from the speed level selection.

#### 5.2.1 PG Joystick

The standard PG Joystick module will be LCD-screen type as shown. You would have received instructions on how to operate your controller at the time of the pre-sale trial and on delivery.

As most power wheelchairs are set up with Drive parameters to suit individuals and their needs, the following are the basic controls for the PG joystick (refer to the diagram on the right):

1. ON/OFF button (press once for ON and again once for OFF)
2. Horn
3. Mode Button (select Seating Functions. Seat Tilt or Recline)
4. Profile Button (select Profile - Indoor or Outdoor drive settings)
5. Speed Button (Sets speed from Low to High in 5 stages)
6. Joystick (Used to steer the wheelchair)

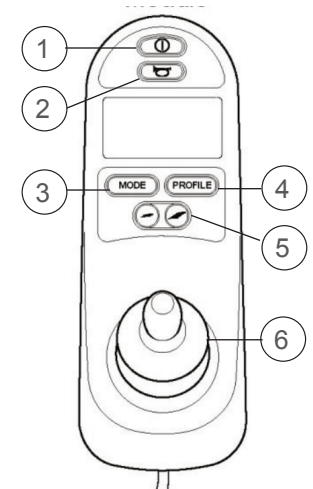

When powered up, the joystick screen should show no error codes and will be ready to drive. If an M1 or M2 Brake Error is showing, this means the motor brake is disengaged. Check the Brake lever on the front of the motors and turn it anti-clockwise to re-engage. See Section 5.3 for further details.

More information relating to PG Controller can be found at [www.glide.com.au](http://www.glide.com.au) under Powered Wheelchairs/CentroGlide/Related Documents/PG Manual.

### 5.2.2 LiNX Joystick

The CentroGlide wheelchair using LiNX controls will come standard with the joystick shown. This Joystick is “Lights ready” meaning, the joystick and power module are ready for fitting optional driving lights.

1. ON/OFF Power Button/Status Indicator
2. Battery gauge
3. Speed dial
4. Connectivity indicator
5. Seat function selector
6. Drive/actuator status
7. Lights and direction indicator - right
8. Horn button
9. Joystick
10. Hazard lights and direction indicator - left
11. Drive function indicator
12. Drive function selector

NOTE: The charger socket position is at the front of the joystick (See A in diagram right).

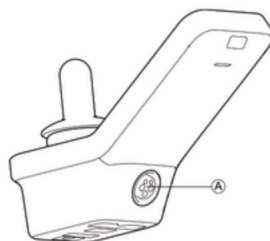
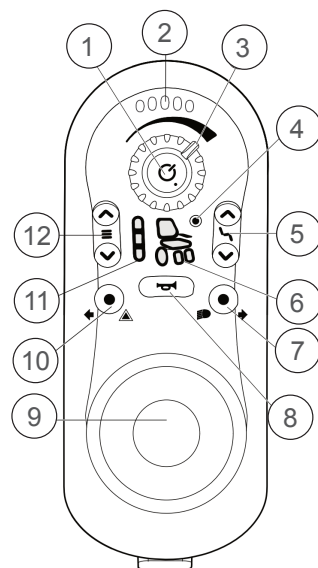

### Operation

When the LiNX remote is powered up and there are no faults with the system, the Status Indicator light is green.

If the light is Red, this could mean there is a fault with the controller.

If the Red light flashes 5 times - one motor brake is disengaged.

If the Red light flashes 6 times - both motor brakes are disengaged.

Check the Brake lever at the front of the motors and turn it anti-clockwise to re-engage. See Section 5.3 for further details.

### Battery Gauge

The battery charging status is shown in the battery gauge.

	<b>Battery is fully charged</b> <b>Maximum driving range</b> Green, green, amber, amber and red LEDs are on.	This level is set by the Batt Gauge Maximum parameter. See LiNX System Manual for more information
	<b>Decreased driving range</b> Red, amber and one green LED on.	
	<b>Decreased driving range</b> Red and two amber LEDs are on.	
	<b>Decreased driving range</b> Red and one amber LED is on. <b>Consider charging battery.</b>	
	<b>Very low driving range</b> Only red LED is on. <b>The battery needs charging.</b>	This level is set by the Batt Gauge Maximum parameter. See LiNX System Manual for more information

### 5.2.3 Optional Attendant Controller

The LiNX Optional attendant controller shown allows the powered wheelchair user's attendant/carer to interact with the LiNX System.

It allows the attendant/carer the control of the Drive, Power seating and connectivity functions (depending on the configuration of the system).



1	Power button/Status indicator	Power up or power down the system. View the system's status. View fault indications (flash codes). Request to be Attendant-in-charge. Lock the system. Emergency stop the wheelchair, if no restriction has been set.
2	Attendant-in-charge indicator	Indicates whether the attendant control unit is in charge of the system.
3	Drive function indicator	Indicates the selected Attendant drive function.
4	Drive wheel/seating indicator	Indicates the selected seating function.
5	Mode button	Allows selection of functions within the attendant profile.
6	Joystick	Controls the speed and direction of the drive and seating function.

### 5.2.4 LiNX REM400 Touchscreen

Your CentroGlide may be fitted with an Optional LCD touchscreen shown.

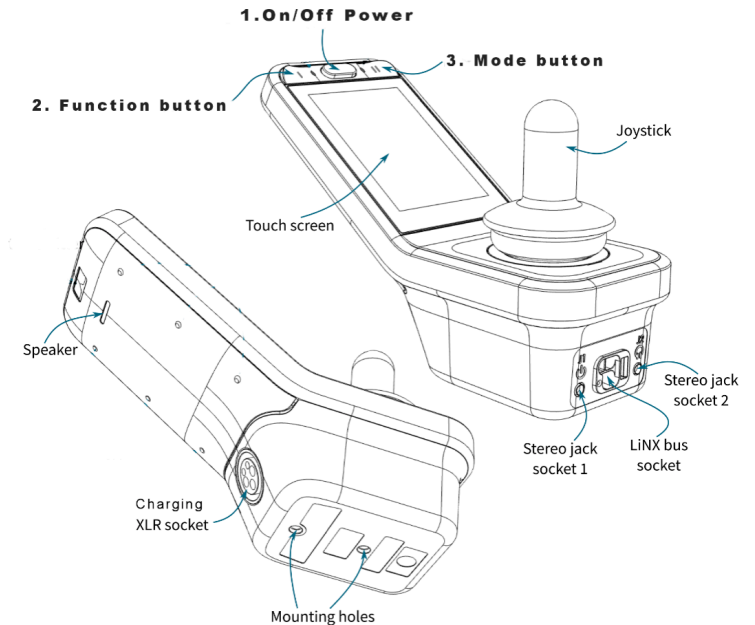

There are many ways the joystick buttons can be set up. However, the following are the CentroGlide standard:

1. Power the ON/OFF button.
2. Function button - to change from the Drive function to the Seating function.
3. Mode button - to change the Drive mode (Indoor / Outdoor) when in the Drive function OR to change the seat operation (Tilt / Recline) when in the Seating function.

(More information relating to LinX Controller can be found at [www.glide.com.au](http://www.glide.com.au) Go to Powered Wheelchairs/CentroGlide/Related Documents/LiNX.

**IMPORTANT:** Please familiarise yourself with the individual functions of your controller in particular the ON / OFF button - press once for ON and press the same button or pad again for OFF.

### 5.2.5 Controller Use Precautions

#### WARNING!

The PG and Dynamic LinX controllers have been designed with user safety as the prime consideration. They incorporate many, sophisticated self-test features that search for potential problems. If the controller detects a problem, either in its own circuits or in the wheelchair's electrical system, it may decide to halt the wheelchair, depending on the severity of the fault. The controllers are designed to maximise user safety under all normal conditions.

Despite their sophistication, the controllers cannot take into account circumstances that put the wheelchair or the controller outside their specified operating conditions. So it is important that the user follows the following precautions.

- NEVER push the ON/OFF button on the Joystick module until you are seated correctly in the chair.
- DO NOT move the joystick when pressing the ON button. An error will occur and you will have to turn the controller OFF and then back ON again. The joystick must be in the central or neutral position to power-on.
- Always set Speed selection to suit the environment. Indoor driving should be set to a lower top speed.
- Driving on highly polished floors and wet or grassy surfaces can lead to a loss of traction. Lower the Speed setting to half or less if required.
- Unless in an emergency, never press the ON/OFF button while driving your power chair.
- NEVER hang items on the joystick (e.g. shopping bags).
- To avoid damage to motor gearboxes always come to a complete stop before turning your power chair OFF.
- Although the controllers are designed and manufactured to be extremely reliable and each unit is rigorously tested, there is always a small possibility of a system malfunction. Under some conditions of a detected system malfunction, the controller will (for safety reasons) stop the chair instantaneously. If the physical impairments of the user are such that sudden braking could result in a fall from the chair, it is advised that a restraining device be fitted to the chair.

#### WARNING!

DO NOT drive the wheelchair:

- If the controller is damaged or other crucial components are known to require repair.
- If there are visible signs of Electrical cable damage.
- If the Joystick shows any signs of damage.

### 5.2.6 Replacing and Servicing Controllers

#### WARNING!

- Never swap Controller parts from another wheelchair.
- All replacement Power Modules will need re-programming by a qualified service technician before use. Damage to motors or unsafe driving parameters may occur.
- The controller supplied with your wheelchair is **specific to that wheelchair** and has been programmed to suit the wheelchair model and the motor type attached.
- Under no circumstances should your controller be swapped with a controller from another wheelchair without strict guidance from your supplier. Doing so may cause the wheelchair to drive erratically and in a dangerous manner.
- All servicing and programming of controllers must be carried out by Glide Products Agents or qualified service technicians.
- If your wheelchair handles poorly after servicing, it may be an indication that the wheelchair has been re-programmed incorrectly and should not be used until the issues are rectified.

 **WARNING!** PG Controls and Dynamic Controls LiNX accept no liability for losses of any kind arising from the unexpected stopping of the wheelchair or improper programming of the controller or improper use of the wheelchair or controller.



### 5.3 Motor Drive - Engage/Disengage

Your wheelchair may be fitted with one of two types of Drive disengagement for manually pushing the wheelchair:

Type 1. Motor Brake disengagement

Type 2. Clutch Drive Wheel disengagement.

#### ⚠ WARNING!

Before disengaging any Drive on your wheelchair please note - the wheelchair will have no braking when Drive is disengaged. Never disengage Drive on a slope as you will have no control of the wheelchair. Only disengage the Drive on a horizontal surface.

#### 5.3.1 Type A - Motor Disengagement

The Motor Brake disengagement Turn Key is located on the front of each motor as shown in the image below. Rotate each Key on both motors clockwise (approx. 45 degrees) to disengage the Motor Brake. The key will snap into position when disengaging.



Once disengaged, the attendant will be able to manually push the wheelchair. Once completed, re-engage the Motor Brake by rotating the Key anti-clockwise until it snaps into position.

#### ⚠ WARNING!

Never leave the wheelchair disengaged. You will not be able to drive the wheelchair while either one or two motors' brakes are disengaged. An error will show up on the joystick module as shown in the image above. You will need to turn the power OFF, re-engaged the Motor Brake and then power up the wheelchair again before use.

#### 5.3.2 Type B – Drive Wheel Clutch Disengagement

The Drive Clutch is located in the centre of each driving wheel. It is identified as a large Black Knob with grip rings (see image below).

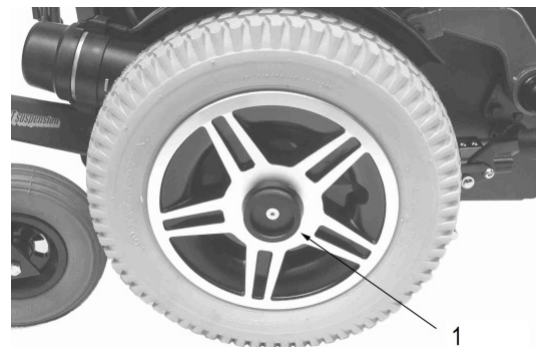

To ENGAGE, simply turn Black Knob (Drive clutch) in either direction until you hear a “click”. Turn the chair on and SET AT SLOWEST SPEED and then SLOWLY move the joystick forward until the drive clutch self-engages. When the clutch is engaged fully, the outer face of the Drive clutch will be flush with the retainer washer.

To DISENGAGE simply pull out the drive clutch and turn 1/8th of a turn or 45 degrees to locate the clutch in the disengaged resting position. This will allow the chair to be free-wheeled. You may need to take some load off the Drive clutch by moving the Drive wheel by hand slightly forwards or backward at the same time as pulling out the Drive clutch.

## 5.4 Brakes

Your power chair has Electronic Brakes. These are activated in the following instances:

- If the chair suffers a power failure while driving.
- When the controller joystick is released.
- When the chair is turned OFF.

**⚠ WARNING!** The Electronic Brake **will not** work if either the Motor Brake or the Drive Clutches are disengaged.

The Electronic Brakes are static brakes only. The wheelchair controller will use the motors for slowing down the wheelchair before the Electronic Brakes are automatically activated.

In addition, the power chair is fitted with the Attendant Static Brakes for use when the chair is stationary. These should be used by an attendant when transporting the occupant in a vehicle or when securing the wheelchair.

## 5.5 Batteries

### 5.5.1 Battery Installation and Removal Procedure

Battery installation should be carried out by a qualified technician as follows:

1. Remove the footrests and set the Seat Tilt to approximately 20 degrees. If no batteries are installed, disconnect the seat actuator cable from the Power module or ISM and, using a suitable connection cable, connect the seat actuator to the battery (12V is OK) and operate the actuator until the seat tilts to 20 degrees.
2. Remove the four securing bolts holding down the Seat Base module.
3. Apply Park Brake and using the Back Cane push handles, tilt the seat base forward. Remove the battery cover and the attached security hook as shown (right).
4. Unscrew and remove the circuit breaker.
5. To avoid accidental shorting of batteries when installing, ensure terminal protection caps are installed. If not, use insulation tape and cover all terminals.
6. Orientate the front battery, lift it into the back of the battery box and slide it forward. Orientate the rear battery and lift it into the battery box. Secure the battery using tie-down bolts and clamps.
7. Connect all wires in accordance with the wiring diagram on page 24.
8. Once completed, detach the security hook, swing it to the back of the chair and locate it in the holder.
9. Insert the plastic Battery Cover on top of the batteries (ensure correct orientation) and lower the Seat Base back down to the chassis.
10. Insert 4 bolts into the base plate and chassis and tighten the nuts.

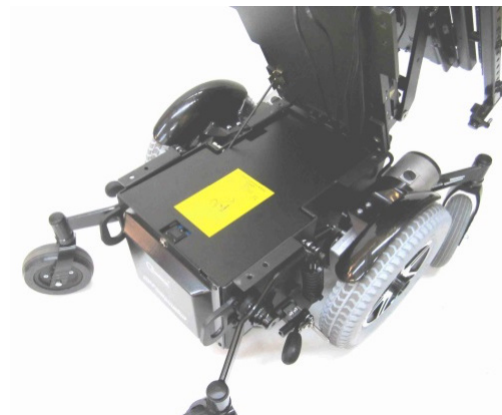



Please adhere to the Battery Installation Warnings on page 25.

If warranted, packing blocks could be used to limit battery movement as batteries come in varying shapes and sizes.

NOTE: The Vertical Lift seat models (post-2013) will hinge from the rear of the wheelchair.

### 5.5.2 Battery Wiring Diagram

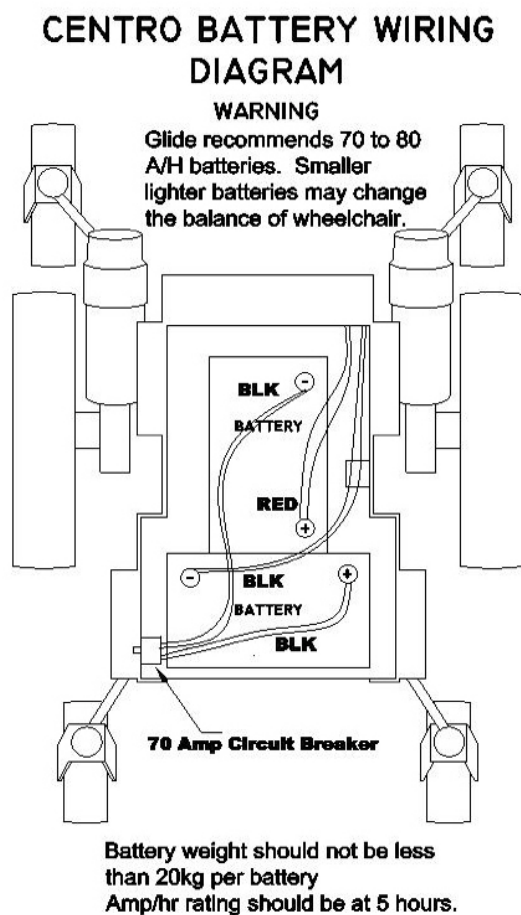

NOTE: If warranted, packing blocks could be used to limit battery movement as batteries come in varying shapes and sizes.

### 5.5.3 Battery Installation Warnings

#### Insulation Cover

##### **⚠ WARNING!**

- The plastic insulating Battery Cover must be in position before securing the Seat Base module to the chassis. Never leave out the plastic insulating cover plate as an electrical short or fire could occur if the batteries become dislodged. The Plastic Insulation cover must be always installed as shown on page 23.
- Ensure the rubber base mat is in place.
- Ensure the battery connectors are secure and the Battery Hold Down bolts are tight using Nyloc nuts.
- If you believe your batteries are not properly secured or have come loose over time, cease driving your wheelchair and have it checked by a service technician.

#### Hinged Seat Base Models

##### **⚠ WARNING!**

The Seat Base must only be hinged forward to remove or insert the batteries. For your safety, never attempt any other maintenance work on the wheelchair other than battery installation whilst the Seat Base is in the hinged position. Damage to the hinge may occur.

#### Battery Types and Sizes

##### **⚠ WARNING!**

Only use batteries with a total combined weight of 40kg or more. Your wheelchair was designed for optimum balance using batteries of this weight. Replacing batteries with smaller or lighter batteries such as the 50Amp/h batteries may change the balance of the wheelchair. Do not use batteries weighing less than 20kg each.

**Recommended Battery Type:** GEL Sealed Lead Acid - Deep Cycle

**Battery Specification:** 2 x 12v 75amp/h approx. weight each 24kg.

**Maximum Battery dimensions:** 260L x 171W x 220H

Consult your Glide Products agent if a battery replacement is required.

### **5.5.4 Battery Charging**

Your power chair Battery Charger is specific to your wheelchair and may not be suitable for other power chairs.

#### **WARNING!**

Only use the charger supplied with your wheelchair. The use of third-party chargers may damage or shorten the life of your batteries.

#### **When Should I Charge the Batteries?**

You should charge after use each day. If the battery indicator light on your controller is in the RED range, you should not drive your wheelchair and must charge it immediately. Driving in the RED range will damage the batteries. The flashing Battery Indicator/Fuel Gauge light is a warning to charge your batteries.

Batteries must be fully charged every 3 months if not in use.

#### **Charging Your Power Chair**

1. Ensure the charger is switched OFF and the controller is OFF.
2. Connect the charger to the wheelchair via the charging socket located on the front of the Joystick module.
3. Turn the power ON at the charger
4. Ensure the charger is properly connected at both ends and check the status lights on the charger.

#### **Charging Operation**

Please refer to specific charging operating instructions supplied with your wheelchair.

#### **Charging Duration**

Charging times may vary depending on usage or battery state of charge, battery size, battery condition and age of the battery. In most cases overnight charging (8 –10 hours) is sufficient. Avoid driving your wheelchair until the batteries are fully charged.

#### **WARNING!**

Undercharged batteries will reduce your driving range and shorten the battery life.

NOTE: The Battery Indicator/Fuel Gauge light on your controller may state that the battery is fully charged. However, this may not be the true indication of charge. The charge level could be as low as 75%. Only your charger will state when the batteries are fully charged.

No harm will be done to the batteries by leaving them on charge after the charging is complete. However, prolonged charging is not advisable, e.g. one or more days.

#### **When is it Time to Replace the Batteries?**

On average, you should get 12 months of life from your batteries before you need to replace them. This is a guide only and depends on many factors including proper charging each night. As the batteries deteriorate, you will notice that the batteries are not lasting as long between charges, and eventually, you will need to replace them as a full charge may only last a couple of hours or less.

### **5.5.5 Battery Care and Storage**

#### **WARNING!**

Do not store the batteries near a heat source or in direct sunlight. Keep the terminals dry. Clean and coat them lightly with petroleum jelly to prevent corrosion.

Batteries must be charged every 3 months if not in use.

## 6. WHEELCHAIR SETUP AND ADJUSTMENTS

Always ensure the CentroGlide wheelchair is adjusted to suit the occupant. This will ensure maximum comfort and safety during use.

It is important the wheelchair is set up correctly by a healthcare professional in conjunction with the Glide Products agent. Your wheelchair may be fitted with a third-party seating systems. Therefore some operations and features may differ from this manual.

### **⚠ WARNING!**

Today, there are many seating systems on the market to fit a multitude of wheelchair types and brands and also to suit individual needs and preferences. The CentroGlide has been designed to accommodate many of these systems including Glide's own. Because of the varying nature of these systems and possible changes to the centre of gravity, it will be necessary for a healthcare professional with the aid of the Glide Products agent representative to ensure the wheelchair is set up safely.

### 6.1 User/Attendant Training

Before using the CentroGlide, it is advisable for both the user/occupant and the carer/attendant to undergo training in all aspects of operation of this power chair by a healthcare professional in conjunction with the Glide Products agent.

### **⚠ WARNING!**

You should always start in a slow Drive Mode selected on the controller and gradually increased speed as you become more proficient in your driving ability. Maximum speeds should be set to suit the user's capabilities.

### 6.2 Armrests Adjustment

The Flip-up armrests are adjustable in height and position - forward or back of the arm pad. These should be made with the occupant sitting in the wheelchair.

The armrests can be permanently set in the desired position and locked with bolts. They can also be user-adjustable using locking knobs or thumb knobs.

#### 6.2.1 Height Adjustment

To adjust the height, loosen the Turn-knob located on the outside of the Armrest Post. When adjustment is complete re-tighten the Turn-knob firmly.

#### 6.2.2 Forward and Back Adjustment of Arm Pad

Loosen the small Turn-knob located on the outside and underneath the arm pad. Re-tighten when adjustment is complete. Do not undo more than one turn. This knob also allows you to adjust the location of the joystick module.

#### 6.2.3 Flip Up Armrest Lock

Located on the inside of the armrest mount bracket. Pull the knob out and turn it 90 degrees. This will allow the armrest to move freely up and down. To lock, turn the knob 90 degrees and allow the knob to drop in. Drop the armrest down. The armrest should be in the locked position.



## 6.3 Footrests and Footplates Adjustment

The footrests are swing-away and detachable. They swing out by pulling the release lever (see right). When the lever is released, the footplate will swing out and lift off the two locating Pins.



### **⚠ WARNING!**

When refitting the footrest to the wheelchair, ensure it is located on both of the locating pins. Damage may result if only one pin is used. Once the legrest is on the locating pins, and with the footplates up, swing the legrest towards the centre of the chair firmly so that the latch will click into position.

### **6.3.1 Height Adjustment of the Footplates**

Your footplate will be fitted with one of two types of adjustment styles.

1. **Clamp-type.** To adjust the height simply loosen the clamp bolt, move to footplate to the desired position and re-tighten the clamp bolt.
2. **Incremental-Hole-type.** To adjust the height, undo and remove the bolt, move the footplate to the nearest hole to suit the desired height, then replace it and tighten the bolt firmly.

## 6.4 Adjusting the Backrest Angle (Recline)

There are two options available for backrest angle adjustment:

1. Standard on all CentroGlide's wheelchairs, unless otherwise ordered, are incrementally adjustable Back Rest canes via the Armrest/Back Canes bracket. It is advisable to have a Glide Products agent or a trained Technician make this adjustment.
2. Electrically operated actuator. This is operated in several ways:
  - The button is located on the controller in conjunction with the joystick.
  - Remote switches are located for best access by the occupant.

Please refer to the respective Controller manufacturer User Guide and familiarise yourself with this function for trouble-free operation.

## 6.5 Adjusting the Seat Angle (Tilt)

Electrically operated actuator. This is operated in several ways:

- The button is located on the controller in conjunction with the joystick.
- Remote switches are located for best access by the occupant
- Changing to the actuator on the MODE setting and using the joystick to adjust.

Please refer to the respective Controller manufacturer User Guide and familiarise yourself with this function for trouble-free operation.



## 6.6 Positioning Belts

The use of positioning belts is highly recommended, as this will help support the occupant and prevent the occupant from falling out. The use of position belts must ONLY be set up by a healthcare professional. Improper use of positioning belts may cause serious injury.

### **⚠ WARNING!**

Positioning belts are not to be used as seat belts when the occupant and the wheelchair are transported in a vehicle. Please refer to Section 10 Transporting Wheelchair Occupant in a Motor Vehicle for further details.

## 6.7 Power Seat Tilt

Your wheelchair will more than likely have a 50-degree power seat tilt which is a common recommendation by healthcare professionals today.

Whether you tilt your seat to the full extent is entirely your choice, but you should be trained in its use and learn to feel safe with this feature. The wheelchair will not drive once it has tilted past 22 degrees, and will have to be returned to a safe level before it can be driven again. The wheelchair must always be on a level surface when tilting past the 22-degree mark.

## 6.8 Power Reclining Backrest

Your Health professional may have prescribed a power reclining backrest with this wheelchair. The user should be trained for the use of this feature and should feel comfortable with its operation.

## 6.9 Other Power Options

Your wheelchair may also have other powered operated options fitted to your wheelchair, which can include:

- Power Elevating Legrests
- Vertical Lift (VR) Raise Seat (Refer to Section 9)
- Power Swing away Chin Control Unit

You must be trained by your Healthcare Professional or your Glide Products agent Representative before using any of these options.

### Pinch Points

#### **⚠ WARNING!**

Before using any power-operated options, ensure everyone is clear of the wheelchair, as pinch points may inflict serious injuries.

All pinch points are clearly marked on the VL (Vertical Lift) unit.

## 6.10 Adjusting the Seat Frame Stop - Service Technicians Only

#### **⚠ WARNING!** This adjustment can only be done by Service Technicians!

The Seat Frame Stop (see A in diagram below) is a safety stop only and is factory set to the correct height.

If adjustment is required, the following procedure must be followed.

Set the Tilt seat actuator in the bottomed (least tilt) position. Then set the adjuster so it is just short of the seat frame by 1 to 2mm.

The stop must not be used as an actuator limit stop. Damage to the actuator or seat frame will occur.

There are two different sizes of stops. Type A (37mm - for Anterior Tilt or 0-degree rake), and Type B (45mm - 4-degree seat rake)

Vertical Lift (VL) wheelchairs do not require this stop.

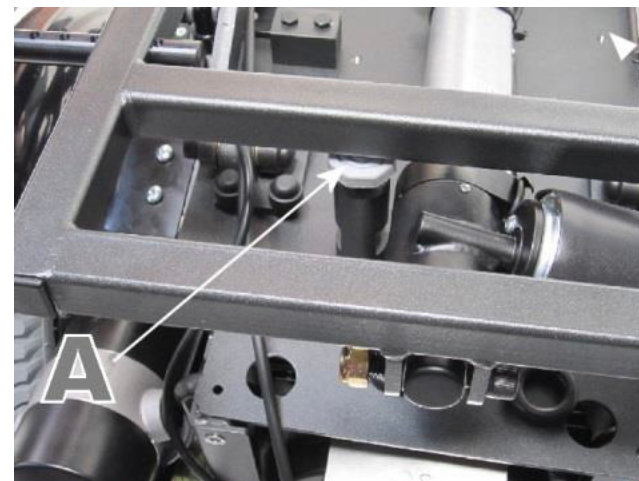



## 7. TRANSFERRING TO AND FROM THE WHEELCHAIR

The CentroGlide power chair is designed to ensure the safe and efficient transfer of the occupant in and out of the chair. However, it is important that the occupant and the attendant/carer learn safe transfer techniques from a healthcare professional.

### **WARNING!**

Note the following when transferring:

- Make sure the chair is turned OFF before transferring the occupant.
- Ensure the wheelchair attendant brakes are applied.
- Armrests can be flipped back to allow for easy lateral movement from either side of the chair or for the fitting of a patient hoist sling.
- If the occupant is ambulant, or able to do standing transfers, removing the swing-away footplates will allow better placement of feet when standing or conversely, closer access to the seat when transferring into chair. Where possible, have someone assist you during the transfer.
- Always have the wheelchair as close as possible to the chair that you are transferring to.
- Ensure that the front castors are facing forward when transferring.
- If your chair is fitted with Power-Operated Seat Tilt or Recline functions, ensure they are in the down and upright position before attempting to transfer.

## 8. SAFE OPERATION OF THE POWER CHAIR

### **WARNING!**

The CentroGlide wheelchair has been designed with user safety as its prime consideration. The user and the attendant must take due care and understand the limitations of the environment that the chair will be operated, and exercise caution in circumstances that put the wheelchair outside the specified operating conditions for which it was designed.

- When driving the wheelchair for the first time you should always start with the slowest speed setting and gradually increase it as you get accustomed to your wheelchair.
- The seat should also be slightly tilted (approximately 8 degrees) for best driving performance.
- Avoid driving your wheelchair when the Seat Tilt is set flat or zero degrees as this may change the driving characteristics. This may also interfere with the ground clearance of the footplates, or the footplates may interfere with the castor wheel.
- In the event of the wheelchair moving in an unexpected manner, release the joystick. This action will stop the wheelchair under any circumstances.
- If your wheelchair is not steering, not performing normally or making strange noises or knocking sounds, cease driving the wheelchair immediately and have a Service Technician examine your wheelchair.

## 9. VERTICAL LIFT (VL) AND LAR MODELS

The Vertical Lift (VL) and LAR versions are similar in operation to the standard CentroGlide but have the added advantage of a 300mm vertical lift. This is ideal if the users are in environments, such as the workplace or the home, where frequent changes in seat height are required.



### **⚠ WARNING!**

Please note the following safety considerations when using the VL and LAR models:

- Max Recommended User Weight = 175kg.
- The VL and LAR models have functions that have crush/pinch points and must be always used with extreme care. All pinch points are clearly marked on the VL (Vertical Lift) unit.
- Before using any of the functions of the Vertical Lift or LAR chair please ensure you have read this section and have been fully instructed and trained on how to use these functions by either your Healthcare Professional or a Glide Products agent.
- Before operating any function of the VL or LAR ensure everyone is well clear of the wheelchair and notify persons within your vicinity of your intention before raising or lowering the lift. **Never operate the VL or LAR if small children are present.**
- Only use the vertical lift functions on firm, level ground.
- For your safety, the wheelchair has been programmed for reduced speed once the lift has been raised from the bottom position. Also, once the seat has been tilted approximately 15 degrees the chair will not drive. The seat must be tilted back below 15 degrees before the chair will drive again.

## 10. TRANSPORTING WHEELCHAIR OCCUPANT IN A MOTOR VEHICLE

The Glide Products CentroGlide is compliant with the Australian Standard AS3696.19 - *Wheeled mobility devices for use as seats in motor vehicles*.

This section covers both the four-point tie-down system and the Dahl Docking station.

Applicable to all CentroGlide models excluding the Bariatric version.

**⚠ WARNING!** THE PRIMARY GOAL OF AS/NZS 3695.19 IS TO REDUCE THE POTENTIAL FOR INJURY TO WHEELCHAIR-SEATED OCCUPANTS IN THE EVENT OF A VEHICLE IMPACT, AND ADDRESS WHEELCHAIR PERFORMANCE RELATED TO NORMAL VEHICLE OPERATING CONDITIONS. ANY MODIFICATIONS OR ADDITIONS TO THE WHEELCHAIR (SUCH AS CHANGES TO THE FRAME, AFTERMARKET CUSHIONS, HARNESES ETC.) MAY REDUCE ITS SAFETY IN A VEHICLE ACCIDENT AND IF UNSURE OF THEIR EFFECT, THE OPERATOR SHOULD CONSULT A SUITABLY QUALIFIED PROFESSIONAL FOR ADVICE.

### 10.1 Safety Considerations

#### **⚠ WARNING!**

- It is safer to be seated in the OEM vehicle seat using the OEM restraint system than seated in a wheelchair using the approved restraint systems.
- For this reason, where feasible, wheelchair users should transfer to the vehicle manufacturer-installed seat using the (OEM) restraint system.
- Wheelchair users should transfer to the vehicle seat and use the vehicle-manufacturer-installed restraint systems whenever it is feasible.
- Unoccupied wheelchairs should be stored in the cargo area and secured during travel.
- The CentroGlide complies with ISO 7176-19 & AS/NZS 3696.19 and has been tested for use in a forward-facing position **ONLY**.



- The user must not weigh more than 159kg for CentroGlide secured with a four-point WTORS and 136kg secured with a Dahl Docking station.
- When the wheelchair is used as Occupant Transport the wheelchair must be in the forward-facing position.
- Use a four-point strap-type wheelchair tie-down. This could be a hook attached to the Tie-down strap end or if no fitting is supplied loop the Tie-down webbing through the securement point to the tie-down (refer to standards below).
- Use a three-point-belt restraint comprising a pelvic-belt restraint and a shoulder-belt restraint that connect near the hip of the occupant.
- Only use the designated Tie-down points located on the wheelchair. Two in the front, and two in the rear.
- Use only a compliant WTORS (Wheelchair Tie-down and Occupant Restraint System) that is installed to the requirements of ISO 10542-1 or ADR 4/04 or AS/NZS 2596 or equivalent.

## 10.2 Crash Test

The CentroGlide VL model was chosen as our test model, being the heaviest of all the CentroGlide models.

The CentroGlide was dynamically tested in a forward-facing test with ATD (test dummy) using both a Four-Point Wheelchair tie-down system and the Dahl Docking Station using a three-point belt restraint comprising a pelvic-belt restraint and a shoulder-belt restraint that connect near the hip of the occupant.

## 10.3 Determining Motor Vehicle Size and Type

The size and type of wheelchair will impact the selection of a vehicle suitable for Wheelchair Occupant transport. Smaller vehicles are generally not suitable for Occupant Transport of powered wheelchairs. The CentroGlide is a mid-wheel drive chair and has good manoeuvrability inside a vehicle. Vehicles with rear entry are the preferred vehicle type.

The best practice for positioning the wheelchair in a vehicle in a forward-facing position is to drive straight in from the rear of the vehicle and avoid manoeuvring inside the vehicle where possible.

To unload a wheelchair, again the best practice is to reverse the wheelchair straight out without manoeuvring inside the vehicle.

### **WARNING!**

Never manoeuvre a wheelchair while it is on a ramp or lifting ramp.

## 10.4 Occupant Vehicle Transport Maximum User Weight

### **WARNING!**

- **Four-Point tie-down system** CentroGlide = **159kg** Score rating = Good (15 out of 16).
- **Dahl Docking Station** CentroGlide = **136kg**

### **WARNING!**

**CentroGlide Bariatric** model may not be suitable for wheelchair occupant transport due to weight limitations.

## 10.5 Wheelchair Securement

The securement of the wheelchair must be in a forward-facing position in a motor vehicle as shown.

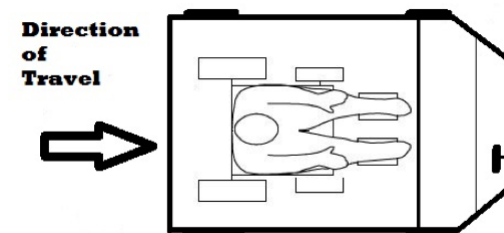

## 10.6 Four-Point Strap-Type Tie-Down System

The Tie-down system used must comply with ISO 10542-1.

This will consist of two Front and two Rear attachment points and occupant restraint belts.

The systems must be fitted and used in accordance with the manufacturer's instructions along with the wheelchair manufacturer's instructions.

### 10.6.1 Securing the Wheelchair with a Four-Point Strap-Type Restraint

#### **⚠ WARNING!**

Standard ISO 10542-1 approved four-point WTORS (wheelchair Tie-down and Occupant Restraint Systems) are only tested to 85kg.

For wheelchairs heavier than 85kg it is recommended to use an ISO 10542-1 WTORS (Heavy-duty system), which is rated for the total weight of the wheelchair including any options.

If using a Heavy-duty System, use four straps to secure the wheelchair, two straps at the front and two straps at the rear.

Never use equipment not labelled with ISO 10542.

### 10.6.2 Tie-Down Strap Angles

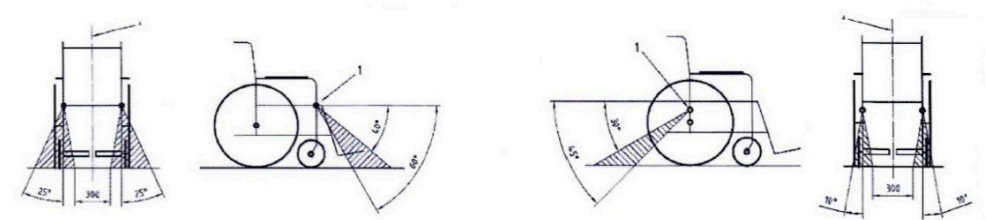

Preferred angles for front  
Tie-down straps

Preferred angles for rear  
Tie-down straps

### 10.6.3 Wheelchair Tie-Down Locations Four-Point

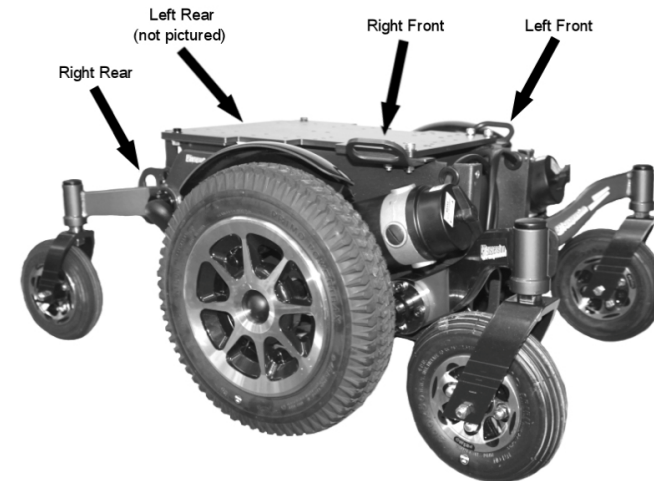

#### **⚠ WARNING!**

Only use the designated Tie-down points on the wheelchair as shown below. DO NOT use any other points for attachment.

Each Tie-down attachment point on the wheelchair will be labelled with the securement decal shown right.

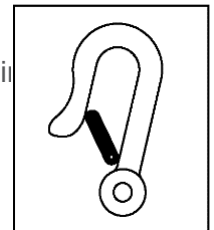

Example of the  
securement decal



### 10.7.2 Dahl / CentroGlide Adaptation Kit #502237 Installation

1. Place the nuts in the pre-drilled battery box reinforcing plate holes and in the battery box with the recess down.
2. Underneath, fit the 8 mm spacer and additional 3mm spacer onto the lock plate and put the five bolts (Dahl #502800) through the lock plate and the spacers.
3. Mount the bolts in the nuts and tighten to a torque of 16-18 Nm.

#### **⚠ WARNING!**

Do not use bolts other than those supplied by Dahl Engineering (part #502800 which is quality 14.9, Torx key size 27). The standard countersunk M8 bolts will not be strong enough in the event of a collision.

4. Cut off excess thread. The fitter must check that the length of the bolts is correct. If bolts are made too short to reach through all threads in the nuts – they will not have the strength to carry the load required. If bolts are made too long the batteries or other wheelchair components can be damaged. If bolts are cut too short replace them with original Dahl bolts #502800 only.
5. Apply Loctite 222 (or an equivalent product) onto threads on all bolts.
6. Place plastic spacers, as shown inside the battery box, to avoid batteries coming into contact with the nuts and bolt ends.
7. Perform the final check by connecting the wheelchair to the docking station. Make sure that the lock plate is securely locked and that all release methods work as intended.
8. **⚠ WARNING!** A warning tone will sound if the lock plate is not properly engaged.



### 10.7.3 CentroGlide Adaptation Kit

The CentroGlide, if not fitted from the standard, must have the following kit installed. This kit comprises a pair of leg hanger mounts (Left and Right side) with 8mm socket screws added as shown right.

This acts as an anti-detach for the leg hangers.



The kit also contains six 8mm x 45mm socket screws with a radius head to replace the existing socket screws as shown with the arrows below.

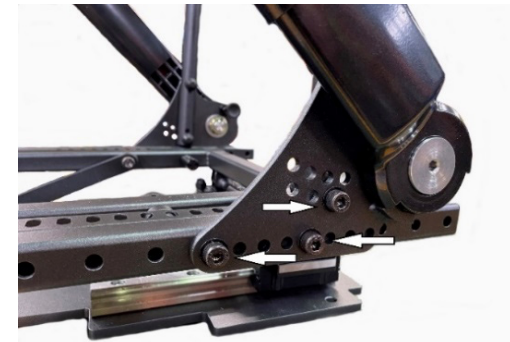

#### **⚠ WARNING!**

The Dahl docking station can be used on CentroGlide models with serial numbers greater than 2203001. Retrofitting may be possible for earlier models but requires modifications to the chassis which can only be carried out by an authorised Dahl installer or Glide Products.





### 10.7.6 Releasing the Wheelchair from the Docking Station

1. When the vehicle has been brought to a halt, remove the safety belt.
2. To unlock commence by driving the wheelchair forward to release pressure on the lock pin.
3. Press the red release button in the control panel. The locking pin will be triggered/ released for approx. 5 seconds, after which the locking pin is automatically locked/activated again.
4. Move the wheelchair away from the docking station within this 5-second period. Do not attempt to reverse out of the docking station until the red LED on the control module, which indicates the unlock position, has been illuminated.

#### **⚠ WARNING!**

Attempting to reverse the wheelchair before the red LED has been illuminated will result in blocking the docking station's locking mechanism, which makes it impossible to reverse. If this happens repeat the above unlocking procedure.

### 10.7.7 Manual Release of Wheelchair from Docking Stations in Case of Electric Failure

A manual emergency release is located at the front edge of the docking station.

1. Move the wheelchair forward to remove the pressure on the lock pin and push the red release arm to one side and hold it there while the wheelchair moves away.
2. A cable-activated manual operating lever can also be fitted (accessory). The red release arm is also pushed to one side and should be held there whilst the wheelchair moves away.

If the described manual release procedures fail, an emergency release tool made from red plastic (shown below) comes with each docking station.

1. Move the wheelchair forward to remove the pressure on the lock pin.
2. Place the emergency release tool in the gap between the locking plate and the docking station.

3. Push the release tool and the wheelchair forward until the locking pin is forced down.
4. Reverse the wheelchair can out of the docking station.

Dahl Engineering offers two docking systems, the Mk II, and a new power height adjustable called Dahl VarioDock. Please also refer to Dahl Engineering instructions for detailed installation, use and maintenance of the system used.

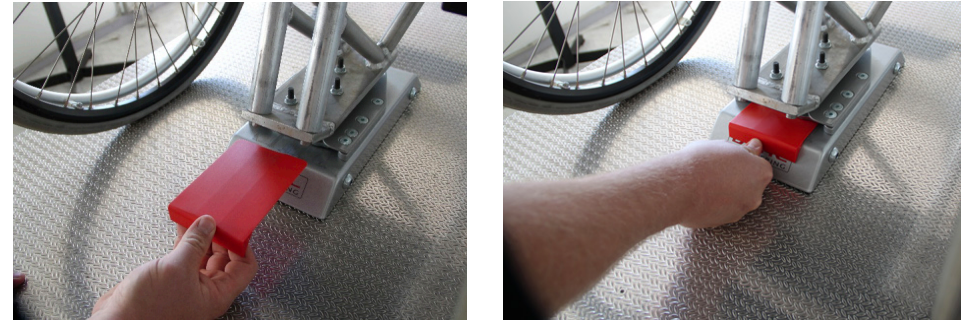

### 10.7.8 Installation of the Dahl Docking Stations in the Vehicle

#### **⚠ WARNING!**

Only professional companies in the business of converting or building wheelchair-accessible vehicles can order the docking system from Dahl Engineering.

#### **⚠ WARNING!**

A qualified and experienced technician must carry out the installation. Dahl Engineering can provide vehicle-specific installation instructions for a large range of vehicles. These instructions must be followed by the technicians.

Please contact Dahl Engineering for further information about approved vehicles and fitting positions at [www.dahlengineering.dk](http://www.dahlengineering.dk)

## 10.8 Wheelchair Set-up for Occupant Transport

### ⚠ WARNING!

- The Seat Tilt must be in the lowest down position.
- The Back recline must be in the furthest upright position.
- The headrest should be adjusted within 50mm of the back of the occupant's head and the centre of the head restraint should be at least as high as the rearward point on the back of the head during normal travel.
- Footplates must have a minimum ground clearance of 100mm.
- Both Shoulder and Pelvic belts must be used to reduce the possibility of head and chest impacts with vehicle components.
- Postural Supports should not be relied on as occupant restraint even if labelled as compliant with ISO 7176-19 or AS/NZS 10542.1
- Tire pressure should be at recommended pressures.
- Motor Brakes must be ON or the Drive Wheel clutch must be engaged.
- Manual Park Brakes must be ON.
- Remove any trays and secure them in a separate section of the vehicle. Trays can also remain secured to a wheelchair positioned out of the way from the occupant with energy-absorbing padding between the tray and the occupant.
- Remove all Auxiliary equipment not bolted to the wheelchair during transport and secure it in a separate section of the vehicle.
- Use ONLY gel cell sealed batteries.
- Alterations should not be made to securement points or the structural frame of the wheelchair without consulting Glide Products.
- Care should be taken when positioning the occupant restraint buckle, so it is not contacted by a wheelchair during a crash.
- The wheelchair should be inspected by Glide Products should it be involved in a collision.

## 10.9 Occupant Restraints

### ⚠ WARNING!

- Only use a three-point-belt restraint that complies with ISO 10542.2, comprising a pelvic-belt restraint and a shoulder-belt restraint that connect near the hip of the occupant.
- Belt restraints should make full contact with the shoulder, chest and pelvis and the pelvic belts should be positioned low on the pelvis near the thigh-abdominal junction. The shoulder belt should fit over the mid-shoulder (see the image below).

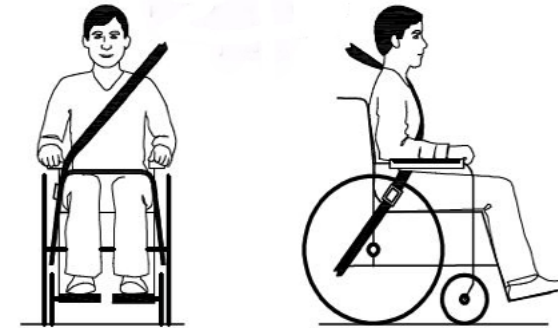

Illustration of correct belt restraint

### 10.9.1 Occupant Restraint Instructions for Use

#### ⚠ WARNING!

- Use a three-point occupant restraint system to secure the occupant.
- Both pelvic and upper torso restraint belts must be used to restrain the occupant to reduce the possibility of any head or chest impacts with the vehicle.
- Any wheelchair-anchored occupant restraint i.e., three-point belt, harness or postural supports (lap straps, lap belts) should not be used or relied on for occupant restraint in a moving vehicle, even if labelled as compliant with ISO 7176.19, SAE J2249 or any other standard. Use a vehicle-anchored and certified occupant restraint system instead.



- Use a suitable headrest for transporting the occupant in a wheelchair.
- Wheelchair-anchored postural supports (lap straps, lap belts) should not be relied on for occupant restraint in a moving vehicle.
- Occupant restraint should make full contact with the shoulder, chest and pelvis and pelvic belts should be positioned low on the pelvis near the thigh-abdominal junction (meeting the requirements specified in ISO 7176.19:2008).
- The upper torso restraint belt must fit over the midpoint of the shoulder and across the chest as illustrated (see image above).
- Restraint belts must be adjusted as tightly as possible consistent with user comfort. Restraint belt webbing must not be twisted when in use.
- Care should be taken when applying the occupant restraint to position the seatbelt buckle so that the release button will not be contacted by wheelchair components while driving or during a crash.
- Belt restraints must not be held away from the body by wheelchair components such as armrests or wheels (see image below).

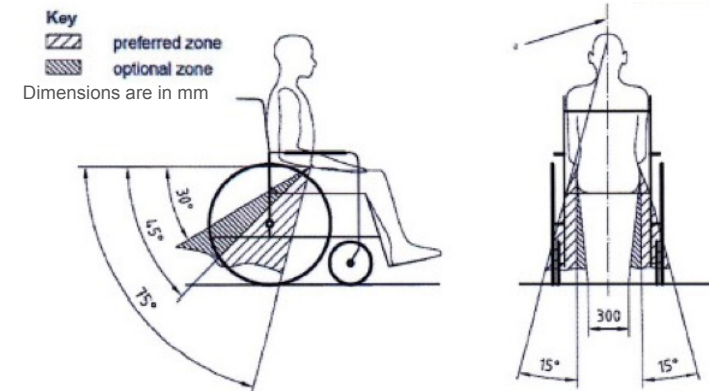

Illustration of incorrect belt restraint

### 10.9.2 Positioning Occupant Restraint Using the Four-Strap Tie-down

#### ⚠ WARNING!

The pelvic restraint belt must be worn low across the front of the pelvis so that the angle of the pelvic belt is within the optional or preferred zone of 30° to 75° to the horizontal. A steeper (greater) angle within the preferred zone, 45° to 75° is desirable, i.e. closer to, but never exceeding 75°.



Preferred and optional angles for locations of the lap belt

The use of a postural Hip Belt (Lap Belt) attached to the wheelchair is recommended only in conjunction with the three-point Belt restraint. The Hip belt is not to be relied on as a restraint.

### 10.9.3 Positioning Occupant Restraint Using the Dahl Docking System Only

#### ⚠ WARNING!

When using a wheelchair with a Dahl Docking system, the floor anchorage points for the occupant restraint system shall be located 10-60mm outside the wheels, on each side.

The pelvic belt must be worn low across the front of the pelvis so that the angle of the pelvic belt is within the optional or preferred zone of 30° to 75° as shown below.

A steeper (greater) angle within the preferred zone, 45° to 75° is desirable, i.e. closer to, but never exceeding 75° (see image below).

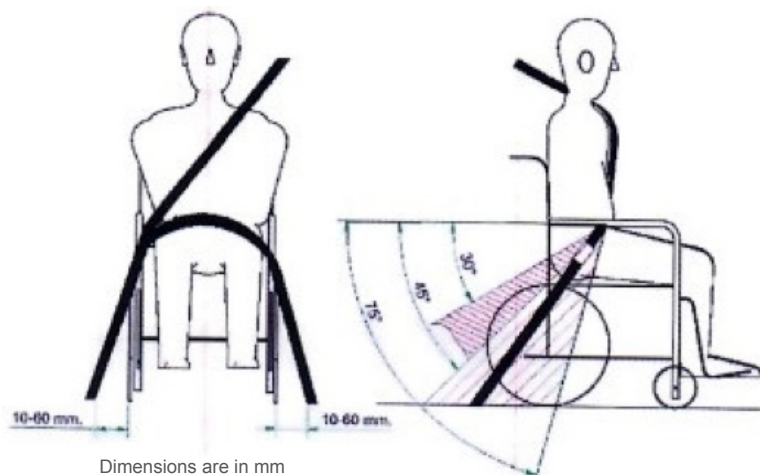

## 10.10 Postural Support Devices

### ⚠ WARNING!

It is recognised that in many cases postural support devices provide support during normal vehicle manoeuvres.

During transportation, postural support devices, where practical, should be removed if they are likely to cause injury in an event of an accident.

Postural support devices should not be removed if the client's safety is likely to be compromised during normal transport.

Postural supports should not be relied on as a crash-worthy occupant restraint regardless of whether they comply with AS/NZS 10542.2 or ADR 4/04 or AS/NZS 2596 or equivalent.

## 10.11 Untested Seating / Backrest

### ⚠ WARNING!

Where a seating system is provided for a wheelchair that was not part of the wheelchair during the AS/NZS 3696.19 crash test, the following considerations should be made with regard to the selection and application of the wheelchair seating requirements:

- Seating components not provided with the wheelchair for testing under AS/NZS 3696.19 should be as light as possible, consistent with clinical function and secured to the wheelchair.
- The seating system must have a backrest that reaches to shoulder height.
- The seating system must have a substantial headrest or head support.
- The minimum restraint requirement recommended is a three-point belt restraint.
- The seating system must comply with Clause 6 of AS3696.10.
- Seating systems that are not part of the wheelchair supplied by the wheelchair manufacturer should be attached to the wheelchair frame without having to drill, weld or glue the fixture to the frame.
- The back support angle during travel should be not greater than 30° to the vertical. It is recognised that there may be instances where this may not be practical.
- The seat reference plane during travel should be greater than 0° to the horizontal. It is recognised that there may be instances where this may not be practical.

## 10.12 Power Reclining Back

### ⚠ WARNING!

In reference to points (g) and (h) above, if the wheelchair is fitted with a Power Reclining back, the Back recline must be in the furthest upright position when transporting. The seat tilt must also be in the furthest down position (the least amount of tilt).

## 11. CARE MAINTENANCE AND REPAIRS

The CentroGlide power wheelchair has been designed for minimal service requirements and will give years of service if used correctly.

### 11.1 Maintenance Schedule

#### Daily

- Charge your batteries every night so your power chair is ready to go when you are.
- Check first up each day that your chair drives as it should. If your wheelchair suddenly drives or reacts differently, it generally means something is wrong and you should cease using the wheelchair until it has been checked by a technician. It could be something as simple as a flat tyre or something more serious.

#### Weekly

- Check tyre pressures and tyre wear or damage.  
Recommended pressure:  
Front castor 206 kpa or 30 psi  
Mid Drive wheel 206 kPa  
Rear castor 206 kpa  
These pressures can be reduced slightly for a softer ride.

#### **WARNING!**

Never use High-Pressure inflators such as the Service Station guns unless regulated. These are fast-flowing guns and could result in over-inflation or explode the tyre. Only use regulated air guns or hand pumps.

- Clean the frame and vinyl parts with a mild soapy solution.
- Wipe the upholstery with a clean damp cloth
- Check all cables for possible damage and ensure all connectors are secured, i.e. battery, motors and controller.
- Check both front and rear castors for any excessive movement above the top or bottom bearing mounts or pintle shaft. Contact your nearest Glide Products agent for repair if this fault occurs.

- Check the function of electric brakes (When the chair is turned ON with the motors engaged and the hand is off the joystick, you should not be able to push the chair or rotate the drive wheels). If the wheelchair can be moved, do not operate the wheelchair. Get a service technician to rectify the fault immediately.

#### Monthly

- Give the chair a general inspection for loose nuts and bolts or any damage.
- Check the attendant park brake is operating correctly.

#### Six-monthly

- Extreme users should have the two front suspension pivot points greased every six months. There are two grease nipples clearly visible on the end of the pivot shaft. Otherwise annually will be sufficient.  
Recommended Grease Type: Molybdenum disulphide 3%  
Brand: Valvoline - Valplex M Grease or similar

#### Annually

- It is advisable to have an annual inspection of the Power Chair performed by an authorised Glide Products agent. Their knowledge and experience enable them to identify and correct problems that might otherwise go undetected.

For any questions concerning maintenance or service procedures, contact your nearest Glide Products selling agent or Glide Products Direct.

### 11.2 Cleaning Wheelchair and Parts

Cleaning should be carried out regularly using a mild soapy solution for all painted surfaces and a damp cloth for all other areas. Always dry off with a clean cloth. Upholstery can be cleaned with a mild detergent and then wiped again with a damp cloth using water only. Leave in an area where it will dry.

### 11.3 Using a High-Pressure Water Cleaner

#### **WARNING!**

Glide DOES NOT recommend using high-pressure cleaners but does concede that on rare occasions it may be necessary. **Before proceeding:**

- All Electrical components including controllers must be removed from the wheelchair before using high-pressure guns.
- Motors must be tightly sealed with a plastic cover and never aim the gun directly at the motors or gearbox.
- Never use alkaline-based solvents or degreasers as they are highly corrosive.

All 4 suspension pivot points should be re-greased using a Molybdenum base grease after High-Pressure Cleaning.

### 11.4 Packing & Shipping the CentroGlide Power Chair

The CentroGlide Power Chair is shipped to Glide Products agents on a pallet enclosed in a cardboard box to minimise damage during transport.

Your chair should arrive to you fully assembled and ready to use.

If your chair needs to be transported interstate or overseas, it is recommended that a shipping box and pallet be used. These can be purchased from your nearest Glide Products agent or dealer.

For any questions concerning maintenance procedures or service, contact your nearest Glide Products agent or Glide Products direct.

### 11.5 User Serviceable Parts / Spare Parts

#### **WARNING!**

The only user-serviceable parts are listed below.

For safety, all other components are to be serviced by Glide Products or a trained technician.

<b>Replacement TYRES</b>	
8" (200*50) Pneumatic Front 8"	Part Number – 202602
8" (200*8) Foam Filled Front (split rim only)	Part Number – 202602A-F
14" Pneumatic (300-8) Drive Wheel	Part Number – 202672
14" Foam Filled (300-8) Drive wheel	Part Number – 202672-F
7" Castor tyre rear (pneumatic)	Part Number – 202603
7" Castor tyre rear (foam filled)	Part Number – 202603A-F
<b>TUBES</b>	
7" (7*1-3/4) Rear (split Aluminium rim)	Part Number – 202493
8" (200*50) Front (split Aluminium rim)	Part Number – 202492-SA
300-8 Drive wheel 14"	Part Number – 202565
<b>Replacement CASTOR WHEEL complete with tyre and bearings</b>	
6" Castor Wheel rear (plastic Hub)	Part Number – 310130
7" Castor Wheel rear foam filled	Part Number – 20120A-F
7" Castor Wheel rear pneumatic	Part Number – 20120A
8" (200*50) Castor Wheel front pneumatic 8"	Part Number – 20121A
8" (200*50) Castor Wheel front foam filled 8"	Part Number – 20121A-F

For more specific spare parts, visit [www.glide.com.au](http://www.glide.com.au) under Spare Parts/ CentroGlide.

## 11.6 Puncture Repair

### 11.6.1 Replacing the Inner Tube on Mid Drive Wheel

1. Raise the wheelchair 25 to 50mm from the ground so the wheel can be removed.
2. Using a 13mm socket spanner, remove the M10 Nyloc Nut and retainer washer from the centre of the wheel as per Fig 1A.
3. Remove the wheel from the gearbox shaft.
4. When reinstalling the wheel, ensure the recessed washer is facing inwards as per Fig 1B and tighten the nut to 26nm torque.



Fig 1A

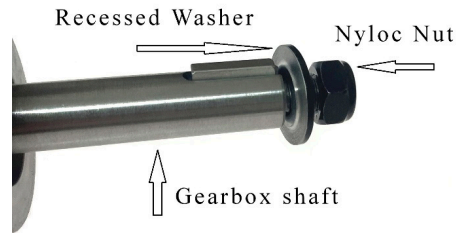

Fig 1B

5. Using a 3/16th socket key, undo all 8 bolts as per Fig 2A below. Before undoing Hex screws, ensure the tyre is deflated.
6. When all screws have been removed, remove the rim half away from the wheel Fig 2B. The inner tube will now be exposed for the re-fitting of the new inner tube. Slightly inflate the tube and insert it into the tyre.



Fig 2A



Fig 2B

7. To re-assemble, replace the tyre on the front side of the rim and line the valve up with the indentation on the rim as arrowed in Fig 2B.

Make sure the tyre is seated correctly and then insert the back half of the rim on the wheel as per Fig 2A. Again, make sure the indentation on the back rim lines up with the valve.

8. You can now gradually re-tighten all 8 screws. All screws need to have a thread-locking compound (Loctite 277™) or equivalent.
9. Do not tighten each screw in one operation. Instead, gradually tighten opposing screws evenly as you go. When all screws are tight you can inflate the tyre to the correct pressure.

The wheel is now ready to be replaced back on the wheelchair. This should be done as follows:

10. Before inserting the gearbox shaft, clean the shaft with a cloth and lightly grease it.
11. Insert a 5mm Key onto the gearbox shaft. Line the hub key-way up with the shaft key and slide the wheel back on.
12. Re-install the retainer washer and Nyloc Nut to the shaft and tighten the nut to 50 nm torque. It is recommended a new nut be used each time.
13. **⚠ WARNING!**

Once the installation is complete, test drive the wheelchair by Stopping / Starting and turning it several times to ensure it drives correctly.



## 11.7 Removing the Castor Wheel

### 11.7.1 Tools Required

To remove the castor wheel from the fork, you will require:

- 2 x 8mm sockets (3/8 sq drive)
- Thread locking compound (Loctite 277 or similar) for assembly



### 11.7.2 Removal Procedure

1. Raise the wheelchair so the castor wheel is 25 to 50mm from the ground. The wheel can then easily be removed from the castor fork.
2. When loosening the bolts, one bolt should stay in tack with the spindle while the other side will loosen. This is because one bolt is secured using high-strength Loctite 680, while the other bolt uses a thread-locking compound, Loctite 277.

### 11.7.3 Reassembly Procedure

1. With one side of the spindle assembled with a washer and bolt, slide the opposing end of the spindle through the fork and wheel until the spindle is flush with the outside of the fork on the opposing side.
2. Once the spindle is located on both sides of the fork, tighten securely (Torque 7.0 Nm) ensuring you use a thread-locking compound on the bolts.

#### **⚠ WARNING!**

You must always re-assemble the castor wheel using a thread locking compound (Loctite 277 or equivalent) on the 5mm bolts. Failing to do so may result in bolts unscrewing.

#### **⚠ WARNING!**

Never use substitute parts. Use only the Glide spindle shaft, 5mm 8.8 bolts and the special washer.

## 11.7.4 Replacing the Inner Tube on the Castor Wheel

1. Remove the wheel (ensure the tyre is deflated).
2. Remove 4 nuts on the wheel as per Fig 3A.
3. Once all 4 bolts have been removed, remove one-half of the hub which will leave the tyre and tube exposed Fig 3B.
4. Remove the old tube and replace it with a new tube. Slightly inflate the tube before inserting a new tube into the tyre.
5. Re-fit the tyre/tube back onto one side of the hub as per Fig 3B ensuring you line the valve up with the valve hole on the hub.
6. Ensure the tyre is seated correctly, then fit the other half of the hub, again ensuring the hub valve indentation lines up with the valve.
7. Replace all 4 bolts (inserting bolts from the valve side of the hub) as per Fig 3A and tighten Dome nuts.
8. Replace the wheel back onto the fork and tighten the bolt. Do not over-tighten. Make sure the wheel spins freely.

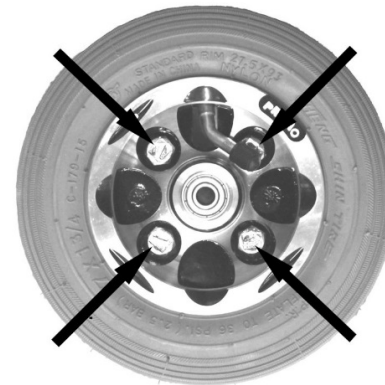

Fig 3A



Fig 3B

## 12. TROUBLESHOOTING

### 12.1 Power Chair Will Not Drive

If your Power chair will not go, follow this procedure:

1. Check the lights on the control Joystick are illuminated.
2. If there are no lights on the controller, check that all leads/plugs that connect to the controller are pushed in and secure.
3. Check for damaged cables.
4. Check the motor cables are properly connected.
5. Check all battery wiring is connected.
6. Check the circuit breaker located at the rear left of the wheelchair and reset it. The circuit breaker will trip when the wheelchair is stalled for a prolonged period or if a major fault has occurred. If the circuit breaker continually trips for no apparent reason, cease use, and contact the nearest Glide Products agent.

**IMPORTANT:** Allow 60 seconds before resetting the circuit breaker.

If you still have problems after reviewing the above checklist, please contact your nearest Glide agent or Glide Products direct.

### 12.2 Power Chair Speed Suddenly Dropped

The wheelchair controller has built-in safety features to reduce damage to the controller and motors. In the event your wheelchair suddenly reduces speed, it may be due to over-heating of the controller. This could happen when going up a long steep hill or if been continually in a stalled situation. Give the wheelchair time to cool and try again. If the problem persists, contact your Glide Products agent.

If the **Smart Drive Encoders** are fitted, and a problem is detected by the controller, the wheelchair speed will be reduced by 50% (Get-you-home mode). It will be safe to continue to drive but all functionality of the encoder will cease to operate until the unit is rectified. Encoders are mounted on the front of each motor. Check the cables for damage or possible disconnection.

If you are unable to rectify the problem, the issue must be addressed by a service technician at your earliest convenience.

## 13. WARRANTY

Glide Products Pty Ltd (ACN 645 050 255) (“Glide Products”) warrants all manufactured and distributed products against defects in materials and workmanship for a period of one year or for a period otherwise stated in this warranty from the date of purchase.

Under normal conditions, no responsibility will be taken for the repair or replacement of any product that has not been used or maintained in accordance with the instructions in this User Manual or is not a direct result of an original manufacturing defect.

Glide Products will repair or replace any part, as determined by Glide Products in its absolute discretion, provided the purchased product is delivered intact and prepaid to a location authorised by Glide Products within the prescribed period of warranty.

The foregoing is in lieu of all other warranties expressed, implied or statutory (except to the extent it is not lawful to exclude them) and Glide Products’ sole liability shall be to repair or replace defective components in accordance with the terms listed below and as determined by Glide Products in its sole discretion.

Glide Products warrants the following for defects in materials and workmanship:

- Chassis 5 year warranty. The Chassis will be replaced within the first five years period. Glide Products will extend the warranty for any such replaced chassis for a further five years, from the date of replacement and will either repair or replace the chassis during that period.
- Upholstery: 12-month warranty. Warranty does not cover against normal wear and tear from reasonable use or damage.
- Tyres and Tubes: 12-month warranty. Warranty does not cover against normal wear and tear from reasonable use or damage.
- Spare Parts: All spare parts will have a 12-month warranty period from the date of purchase.
- Controllers/Battery Charger: 12-month warranty. Controllers and associated hardware will be repaired where possible. Replacement will only occur if repair is not practical or not possible.



- Motors/Gearbox/Actuators: 12-month warranty. Automatic replacement within six months of purchase. Thereafter, the unit must be returned for evaluation and possible repair before replacement.

If any faults are detected during normal use, please notify the Glide Products agent from whom you purchased the wheelchair, or Glide Products directly to ascertain if warranty conditions apply and to organise repair or replacement as determined by Glide Products in its absolute discretion.

### **13.1 Limitation of Liability and Exclusions**

Only Glide Products wheelchairs purchased at full price from a Glide Products agent are warranted against defective workmanship and materials.

Glide Products does not warrant either expressly or impliedly the suitability of the (product name) wheelchair for the purchaser or any intended user. Purchasers and intended users are advised to seek advice from an appropriate medical practitioner prior to using the Glide Powered wheelchair.

Glide Products will not accept responsibility for any damage or injury caused by misuse or non-observance of the instructions set out in this User Manual.

Glide Products will not guarantee the safe and correct functioning of the wheelchair if any of the original components have been modified or replaced with non-original Glide Products parts. Unauthorised modifications or use of unsuitable spares will also void the warranty.

This warranty does not extend to parts or components subjected to negligence, accident, improper assembly/installation by the purchaser, incorrect programming, operation, storage or maintenance, unauthorised modifications to the wheelchair including, but not limited to, modifications to the original components through the use of non-original Glide Products parts or attachments, products damaged by reason of repair made to any component without authorisation from Glide Products, or to products damaged by circumstances beyond Glide Products' control, and such evaluation will be solely determined by Glide Products.

The warranty does not extend to problems arising from or any situation that could be deemed as fair wear and tear or misuse.

The warranty does not extend to any cosmetic or superficial defects, dents, marks or scratches which do not influence the proper and intended function of the products.

The warranty does not extend to any product purchased second-hand or from a person who is not an authorised Glide Products agent.

The warranty on this product does not include labour or freight charges incurred in replacement part installation or repair of the product.

Except insofar as is prohibited by statute, Glide Products shall not be liable for consequential or incidental damage, injury or loss of any kind to any property or person whatsoever arising from or in connection with the Glide Products wheelchair.

## 14. TECHNICAL SPECIFICATIONS

<b>Max Recommended User Weight</b>	175kg AS 3695 Full compliance – Class B Indoor/Outdoor
<b>Wheelchair weight</b>	85kg (without batteries and upholstery)
<b>Operational Weight</b>	Typical operational wheelchair weight 132kg – 150kg
<b>Rear Castors</b>	7 " pneumatic (optional 6" or 8")
<b>Front Castors</b>	200 -50 (8") pneumatic (optional 7")
<b>Drive Wheels</b>	3.00 – 8 (14"), Optional 14" or 12" wide
<b>Suspension</b>	APT
<b>Overall Length</b>	900mm (foot plate removed)
<b>Overall Width</b>	620mm (wheel base)
<b>Seat Width</b>	31, 34, 37, 40, 43, 46, 49, 52, 55, 58, 61cm
<b>Seat Depth</b>	31, 34, 37, 40, 43, 46, 49, 52, 55, 58cm
<b>Seat Height</b>	46cm (top of rail using 0-46 set up)
<b>Back Height</b>	1030mm Top of push handle (custom height available)
<b>Seat Tilt</b>	4-50 std (optional 0-46 degree)
<b>Arm Rests</b>	Flip up (adjustable)
<b>Leg Rests</b>	Swing away detachable
<b>Frame Colour</b>	Choose from Glide colour range
<b>Brakes</b>	Electronic and manual park
<b>Max Ramp</b>	12° Incline /Decline
<b>Controls</b>	PG or LiNX
<b>Battery</b>	70-90 amp/hr (260Lx170Wx220H) Sealed
<b>Range</b>	40 km max with 70 amp/hr
<b>Approvals and Compliance</b>	TGA – ARTG #95730, AS3695, AS 3696.19

## 15. DISPOSAL AND RECYCLING

At the end of its useful life, your CentroGlide power chair must be recycled.

Disposal of any component must be carried out in accordance with national and local government provisions.

- The metal components can be disposed of at your nearest scrap metal collection facility.
- Electric components and printed circuit boards can be disposed of as electronic scrap at your nearest waste management facility.
- Depleted or damaged batteries must be disposed of at your nearest battery collection facility. Please contact your local Council for locations. DO NOT put them in your regular rubbish bin.

Please contact your Glide Products agent or Glide Direct for further advice.







**Glide Products are manufactured in Australia**

**66 Prindiville Drive, Wangara**

**Western Australia 6065**

**Phone +61 8 9345 3400**

**Email: [sales2@glide.com.au](mailto:sales2@glide.com.au)**

**Web: [www.glide.com.au](http://www.glide.com.au)**

**ABN 28 645 050 255**

**ACN 009 033 694**

**ISO 9001 Accredited**

**A wholly Australian-Owned Company**